



A division of
WGI Westman Group Inc.



Stormwater Treatment and Flow Control

Armtec is excited to partner with Hydro International to provide a full line of stormwater treatment solutions. Each device delivers proven, measurable and repeatable surface water treatment performance and can be used independently to meet the specific treatment needs of a site or combined to form a stormwater management train. With the growing trend towards regulated municipal stormwater management, Hydro International's treatment systems are designed to remove trash, oil, heavy metals and other contaminants from surface water. Installed in conjunction with a stormwater collection system they are sized to meet the site-specific flow, removal efficiency and target particle size requirements.



The Canadian Environmental Technology Verification (ETV) Program is a nationally recognized program that provides independent validation of environmental performance claims for innovative technologies, processes, and products.

The New Jersey Corporation of Advanced Technologies (NJCAT) verifies the testing of Manufactured Treatment Devices (MTDs) relative to the performance claims. Only with verification by NJCAT will the **New Jersey Department of Environmental Protection (NJDEP)** certify the verification. These processes provide objective and quality-assured performance data on environmental technologies so that users, developers, regulators, and other stakeholders can make informed decisions about purchasing, applying and regulating these technologies.

Downstream Defender®

Capture and retain sediment, oils and floatables from stormwater runoff over a wide range of flows in a small footprint.

Downstream Defender® is an advanced hydrodynamic vortex separator that provides impressive and reliable removal of sediments, oil and floatables from stormwater runoff.

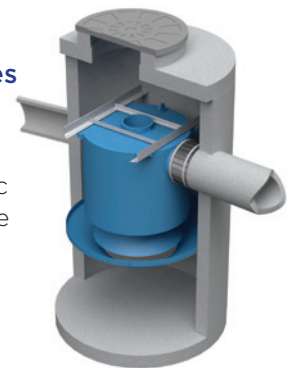

First Defense®

Capture and retain stormwater sediment, trash and floatables in a unit that saves site space and adapts to smaller or logistically difficult site locations.

First Defense® is a versatile stormwater separator that works with single and multiple inlet pipes and inlet grates. It is easily maintained from the surface by a standard vacuum tanker.

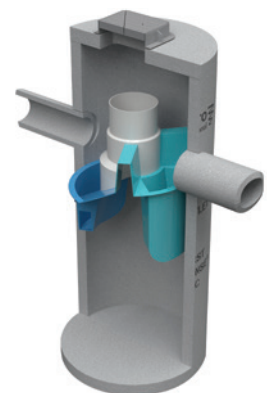

Key Pollutants

| Product | Description | Catchment Size | | | Target Particle Size (Average) (Microns) | Targeted Pollutants |
|----------------------|---|----------------|--------|-------|--|--|
| | | Small | Medium | Large | | |
| FIRST DEFENSE® | Vortex separator | ✓ | | | 240** | Coarse sediment, litter, debris and hydrocarbons |
| DOWNSTREAM DEFENDER® | Advanced hydrodynamic vortex separator | | ✓ | ✓ | 160** | Fine sediment, litter, debris, hydrocarbons, metals and nutrients |
| UP-FLO FILTER™ | Fluidized bed up-flow filtration system | ✓ | ✓* | | 20 | Very fine sediment, litter, debris, hydrocarbons, metals and nutrients |

* With the use of vault design

** May be sized for different target particle sizes and removal efficiencies – [Contact an Armtec representative for site specific design.](#)

Up-Flo Filter®

Capture sediment, debris, heavy metals, oil and nutrients from stormwater while reducing your site footprint and cutting maintenance costs.

The Up-Flo® Filter is an advanced stormwater treatment solution that combines sedimentation and screening with filtration to deliver exceptional stormwater pollution removal.



Helping people improve the way they process, treat and manage water.

Hydro International is a global company that provides advanced products, services and expertise to help municipal, industrial and construction customers improve their water management processes, increase operational performance and reduce environmental impact.

With over 30 years of experience and a reputation for engineering excellence, businesses and public organizations all over the world rely on their products and services to improve water treatment and protect the environment from water pollution.

Hydro-Brake® Vortex Flow Control

Regulates low, moderate and high flows to deliver low-impact drainage from single sites to large networks.

The Hydro-Brake® vortex flow control provides customized water quantity management across a wide range of flows and for a variety of applications.



Downstream Defender®

The Downstream Defender® is an advanced vortex separator used to treat stormwater runoff in pretreatment or stand-alone applications. Its unique flow-modifying internal components distinguish the Downstream Defender® from conventional and simple swirl separators that typically bypass untreated peak flows to prevent washout of captured pollutants. The Downstream Defender treats the entire storm with no washout or untreated bypass flows. Its wide treatment flow range, low head loss, small footprint and low-profile make it a compact and economical solution for capturing non-point source pollution.

The Downstream Defender's innovative design delivers high efficiency across a wide range of flows in a much smaller footprint than conventional or other swirl-type devices. It is the perfect choice for any catchment likely to convey high quantities of contamination.

TYPICAL APPLICATIONS

- Commercial and residential developments
- Industrial areas
- Streets and highways
- Projects requiring NJCAT and NJDEP verification
- LEED® development projects
- Projects requiring ETV verification



ENVIRONMENTAL PROTECTION

- Captures and retains a wide range of Total Suspended Solids (TSS), floatable trash and petroleum products



VERSATILE

- Accommodates change in outlet pipe direction without the need to construct a second manhole



QUALITY

- Treats the entire storm with no washout or untreated bypass flows



EASE OF INSTALLATION

- Variable inlet/outlet angles for ease of site layout
- Delivered to site as a precast concrete manhole chamber with pre-assembled internal components

FIG.1 The Downstream Defender® has internal components designed to maximize pollutant capture and minimize pollutant washout

Components

1. Inlet to Precast Vortex Chamber
2. Cylindrical Baffle
3. Center Shaft
4. Outlet Pipe
5. Sediment Storage Sump
6. Access Lid

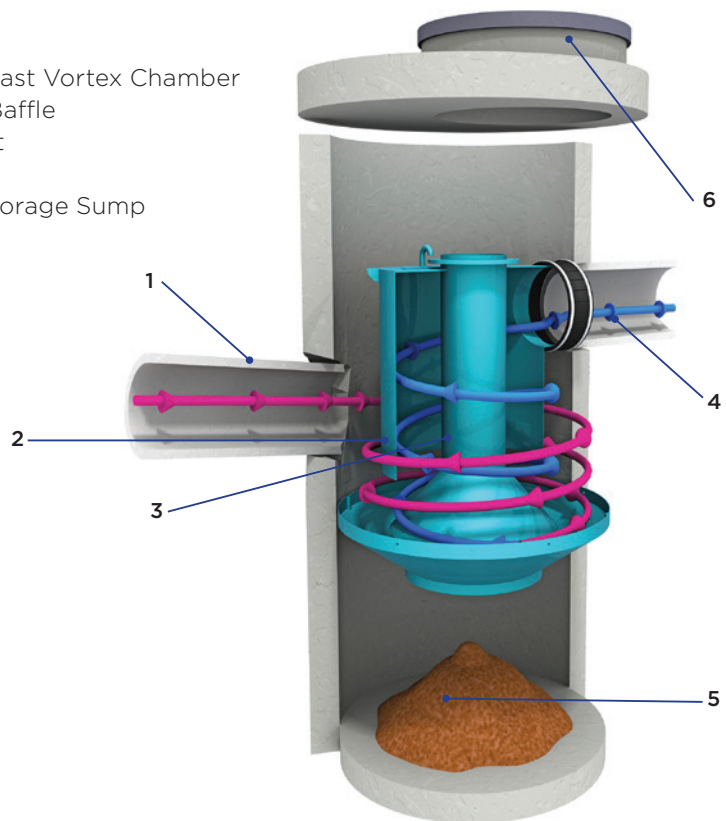

Downstream Defender has been verified by the **Canadian Environmental Technology Verification Program (Canadian ETV)**.

Drainage Profile

The Downstream Defender® is designed with a submerged tangential inlet to minimize turbulence within the device. Turbulence increases system head losses and reduces performance by keeping pollutant particles in suspension. The inlet elevation of the Downstream Defender® is located one inlet pipe diameter lower than the elevation of the outlet invert (Fig.3). This arrangement ensures that influent flows are introduced to the treatment chamber quiescently below the water surface elevation, minimizing turbulence. The unique flow-modifying internal components also minimize hydraulic losses. There are no internal weirs or orifices; large clear openings ensure low head loss at peak flow rates with little risk of blockages that cause upstream flooding.

Sizing & Design

The Downstream Defender® can be used to meet a wide range of stormwater treatment objectives. It is available in 5 models that fit easily into the drainage network (Table 1). Selection and layout of the appropriate Downstream Defender® model depends on site hydraulics, site constraints and local regulations. Both online (Fig.2a) and offline (Fig.2b) configurations are common.

FIG.2a The Downstream Defender® in an online configuration

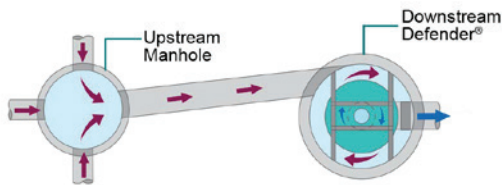
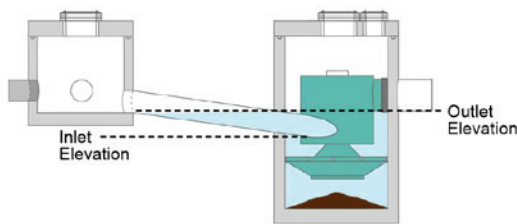

FIG.3 The Downstream Defender® has a submerged inlet that reduces head loss and improves efficiency of pollutant capture



Inspection & Maintenance

Proper equipment inspection and maintenance is critical for ensuring optimal, ongoing device performance. Downstream Defender® maintenance is easy and safe and requires only a standard sump vacuum to remove pollutants. Confined space entry or removal of components is not necessary.



FIG.2b The Downstream Defender® in an offline configuration

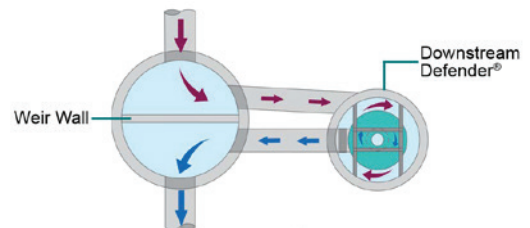

Free Stormwater Sizing Tool

This simple online tool will recommend the best separator, model size and online/offline arrangement based on site-specific data entered by the user.

Go to hydro-int.com/sizingtool to access the tool.



TABLE 1: Downstream Defender® Design Criteria

| Model Diameter | | Peak Treatment Flow Rate | | Maximum Pipe Diameter | | Oil Storage Capacity | | Sediment Storage Capacity | | Minimum Distance from Outlet Invert to Top of Rim | | Standard Height from Outlet Invert to Sump Floor | |
|----------------|------|--------------------------|-------|-----------------------|------|----------------------|-------|---------------------------|-------|---|------|--|------|
| (mm) | (ft) | (L/s) | (cfs) | (mm) | (in) | (L) | (gal) | (m³) | (yd³) | (m) | (ft) | (m) | (ft) |
| 1,200 | 4 | 85 | 3.0 | 300 | 12 | 265 | 70 | 0.53 | 0.70 | 0.85 | 2.8 | 1.25 | 4.1 |
| 1,800 | 6 | 227 | 8.0 | 450 | 18 | 818 | 216 | 1.61 | 2.10 | 0.98 | 3.2 | 1.80 | 5.9 |
| 2,400 | 8 | 425 | 15.0 | 600 | 24 | 2,044 | 540 | 3.56 | 4.65 | 1.28 | 4.2 | 2.35 | 7.7 |
| 3,000 | 10 | 708 | 25.0 | 750 | 30 | 3,975 | 1,050 | 6.65 | 8.70 | 1.52 | 5.0 | 2.85 | 9.4 |
| 3,700* | 12* | 1,076 | 38.0 | 900 | 36 | 6,700 | 1,770 | 11.24 | 14.70 | 1.71 | 5.6 | 3.41 | 11.2 |

*Not available in all areas. Please contact an Armtec representative for details.

First Defense® High Capacity

The First Defense® High Capacity is an enhanced vortex separator that combines an effective stormwater treatment chamber with an integral peak flow bypass. It efficiently removes total suspended solids (TSS), metals, trash and hydrocarbons from stormwater runoff without washing out previously captured pollutants. The First Defense® High Capacity is available in several model configurations to accommodate a wide range of pipe sizes, peak flows and depth constraints (Table 2).

Suitable for at-source pollution control in small to medium catchments, the First Defense® provides space saving, easy-to-install surface water treatment in a standard size manhole which is verified by both the New Jersey Comprehensive Assessment Tool (NJCAT) and New Jersey Department of Environmental Protection (NJDEP).

TYPICAL APPLICATIONS

- Commercial and residential developments
- Industrial areas
- Streets and highways
- Pretreatment for filters, infiltration and storage
- Projects requiring NJCAT and NJDEP verification





|  ENVIRONMENTAL PROTECTION |  VERSATILE |  QUALITY |  EASE OF INSTALLATION |
|---|--|---|---|
| <ul style="list-style-type: none"> • Treats stormwater to remove sediment, metals, litter and floatables | <ul style="list-style-type: none"> • Suitable for single or multiple inlet pipes and inlet grates • Adapts to smaller or logistically difficult site locations | <ul style="list-style-type: none"> • Proven to prevent pollutant washout at up to 450% of its treatment flow • Repeatable, reliable performance | <ul style="list-style-type: none"> • Internals delivered to site pre-assembled and ready for installation • No need to construct external bypass control structures |

FIG. 4
The First Defense® High Capacity has internal components designed to efficiently capture pollutants and prevent washout at peak flows.

Components

1. Inlet Grate (optional)
2. Precast Chamber
3. Inlet Pipe (optional)
4. Floatables Draw Off Slot (not pictured)
5. Inlet Chute
6. Internal Bypass
7. Outlet Pipe
8. Oil and Floatables Storage
9. Outlet Chute
10. Sediment Storage Sump

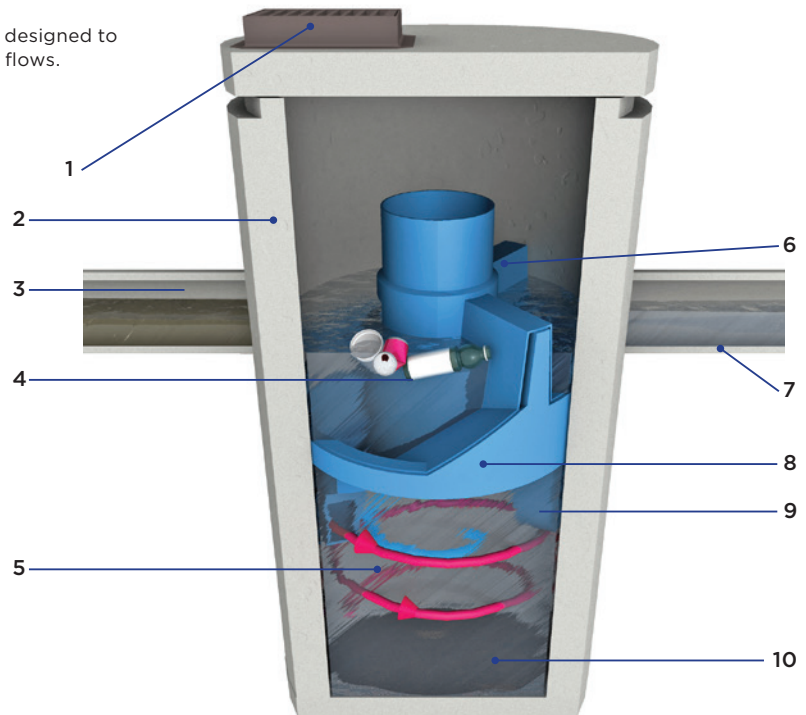

Verified by NJCAT and NJDEP

Sizing & Design

This adaptable online treatment system works easily with large pipes, multiple inlet pipes, inlet grates and now contains a high capacity bypass for the conveyance of large peak flows. Designed with site flexibility in mind, the First Defense® High Capacity allows engineers to maximize available site space without compromising treatment level.

Free Stormwater Separator Sizing Calculator for Engineers

This simple online tool will recommend the best separator, model size and online/offline arrangement based on site-specific data entered by the user. For assistance please contact an Armtec representative.



Go to hydro-int.com/sizingtool to access the tool.

Inspection & Maintenance

Maintenance is safe and easy with a standard vector truck, with no need to enter the confined space. Maintenance consists of removing sediments from the sump and floatable oils, grease, litter and other debris from the floatables capture zone.

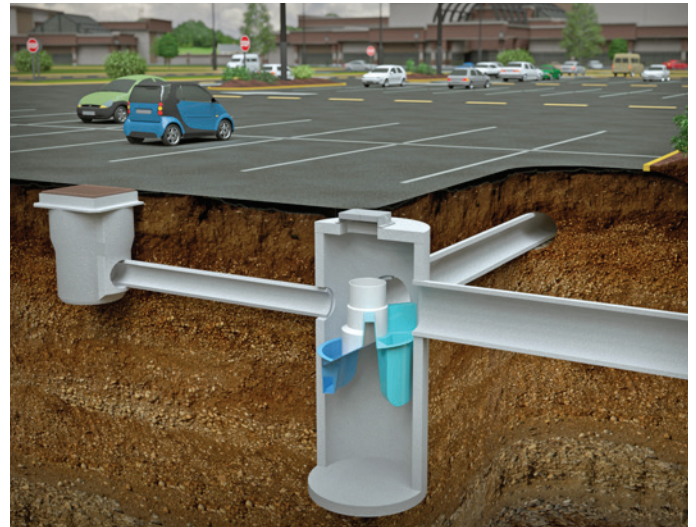

FIG.5 Works with multiple inlet pipes and grates



FIG.6 Maintenance is done with a vector truck

TABLE 2: First Defense® High Capacity Design Criteria

| First Defense® High Capacity Model No. | Diameter (mm/ft) | Typical TSS Treatment Flow Rates | | Peak Online Flow Rate (L/s / cfs) | Maximum Pipe Diameter ¹ (mm/in) | Oil Storage Capacity (L/gal) | Typical Sediment Storage Capacity ² (m ³ /yd ³) | Minimum Distance from Outlet Invert to Top of Rim ³ (m/ft) | Standard Distance from Outlet Invert to Sump Floor (m/ft) |
|--|---------------------|----------------------------------|----------------------|--------------------------------------|---|---------------------------------|--|--|--|
| | | NJDEP Certified (L/s / cfs) | 106µm (L/s / cfs) | | | | | | |
| FD-3HC | 0.9 / 3 | 23.7 / 0.84 | 45.3 / 1.60 | 424 / 15 | 457 / 18 | 473 / 125 | 0.3 / 0.4 | 0.6 - 1.0 / 2.0 - 3.5 | 1.13 / 3.71 |
| FD-4HC | 1.2 / 4 | 42.4 / 1.50 | 53.2 / 1.88 | 510 / 18 | 610 / 24 | 723 / 191 | 0.5 / 0.7 | 0.7 - 1.2 / 2.3 - 3.9 | 1.5 / 4.97 |
| FD-5HC | 1.5 / 5 | 66.2 / 2.34 | 83.3 / 2.94 | 566 / 20 | 610 / 24 | 1,135 / 300 | 0.84 / 1.1 | 0.7 - 1.3 / 2.5 - 4.5 | 1.5 / 5.19 |
| FD-6HC | 1.8 / 6 | 95.7 / 3.38 | 133.9 / 4.73 | 906 / 32 | 762 / 30 | 1,878 / 496 | 1.2 / 1.6 | 0.9 - 1.6 / 3.0 - 5.1 | 1.8 / 5.97 |
| FD-8HC | 2.4 / 8 | 169.9 / 6.00 | 212.9 / 7.52 | 1,415 / 50 | 1,219 / 48 | 4,239 / 1,120 | 2.1 / 2.8 | 0.9 - 1.8 / 3.0 - 6.0 | 2.2 / 7.40 |

¹Contact an Armtec representative when larger pipe sizes are required.

²Contact an Armtec representative when custom sediment storage capacity is required.

³Minimum distance for models depends on pipe diameter.

Up-Flo® Filter

The Up-Flo® Filter is a multi-stage stormwater treatment system that combines pretreatment with fluidized bed filtration technology in one structure for superior filtration rates and media longevity. The Up-Flo® Filter optimizes the balance between high treatment performance and total cost of ownership.

Designed with efficiency, longevity and upkeep in mind, the Up-Flo® Filter has high loading rates and long media life. The upflow fluidized bed technology prevents clogging of the filter media. A high flow bypass and trap for oils and trash is integrated into the design. The Up-Flo® Filter is independently verified through the TARP field monitoring program.

TYPICAL APPLICATIONS

- Residential and commercial areas
- Industrial developments
- Streets and highways
- LEED® construction projects
- Projects requiring NJCAT and NJDEP verification





| | | | |
|--|--|--|--|
|  ENVIRONMENTAL PROTECTION |  VERSATILE |  QUALITY |  EASE OF MAINTENANCE |
| <ul style="list-style-type: none"> • Certified removal rate of 80% TSS by the New Jersey Department of Environmental Protection | <ul style="list-style-type: none"> • Modular filtration components allow adaptation to any catchment area | <ul style="list-style-type: none"> • Increased treatment efficiency in multi-stage treatment device | <ul style="list-style-type: none"> • Media bags are easily removed and replaced without purchase of new cartridge |

FIG.7 The Up-Flo® Filter includes sedimentation, screening and filtration in a single device

System Components

1. Inlet Grate (pictured) or Inlet Pipe (not shown)
2. Precast Filtration Chamber
3. Filter Module
4. 4mm Screening
5. Bypass Hood/Siphon
6. Outlet Module with Drain Down Filter
7. Pollutant Storage Sump
8. Media Bags

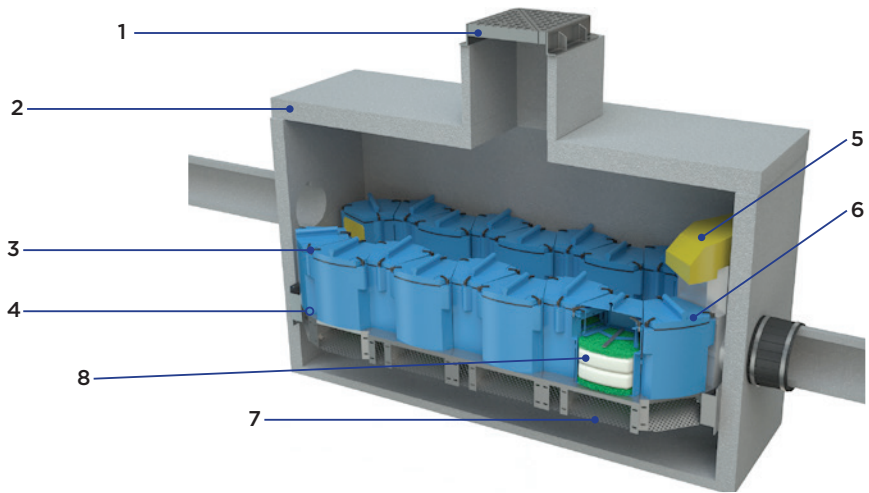
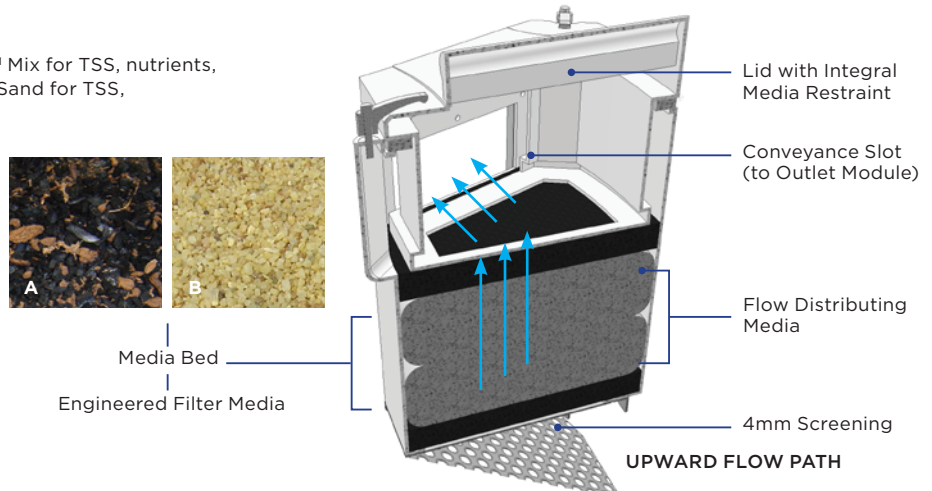

FIG.8 Engineered media mixes include (A) CPZ™ Mix for TSS, nutrients, metals and organics removal or (B) Hydro Filter Sand for TSS, particle-bound nutrients and metals removal

Filter Module Components

Each filter module contains two filter bags containing an engineered media mix designed to optimize pollutant removal by evenly spreading the flow across the entire surface area.



Sizing & Design

The modular design of the Up-Flo® Filter ensures that project specific treatment goals are easily met.

Standard and typical dimensions are listed below. Use our sizing calculator to determine appropriate site-specific sizing.

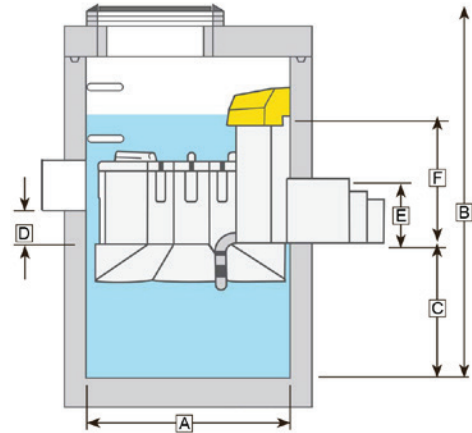

TABLE 3: Up-Flo® Filter Design Criteria

| Chamber | A Diameter (mm/ft) | Maximum Filter Modules (No.) | B Height (m/ft) | C Sump Depth (m/ft) | D Inlet/Outlet Drop (m/ft) | E Maximum Pipe Diameter (mm/in) | F Operating Head (m/ft) | Maximum Treatment Flow (L/s / cfs) |
|-----------------|--------------------------|---------------------------------|-----------------------|---------------------------|----------------------------------|---------------------------------------|-------------------------------|---------------------------------------|
| Round Manhole | 1,200 / 4 | 6 | 2.29 / 7.5 | 0.91 / 3.0 | 0.24 / 0.8 | 375 / 15 | 0.76 / 2.5 | 1.586 / 0.056 per module |
| Rectangle Vault | 1,800 x 2,400 / 6 x 8 | 7 | 1.98 / 6.5 | 0.60 / 2.0 | | 609 / 24 | | |
| | 1,800 x 3,900 / 6 x 13 | 18 | | | | | | |
| | 2,500 x 3,900 / 8.5 x 13 | 36 | | | | | | |
| | 4,500 x 3,900 / 15 x 13 | 54 | | | | | | |

Inspection & Maintenance

Regular inspection and maintenance is critical to ensure optimal device performance.

Filter modules are situated along chamber walls enabling easy sump access for vactor trucks. Light-weight media bags can be manually replaced without removing the entire module.

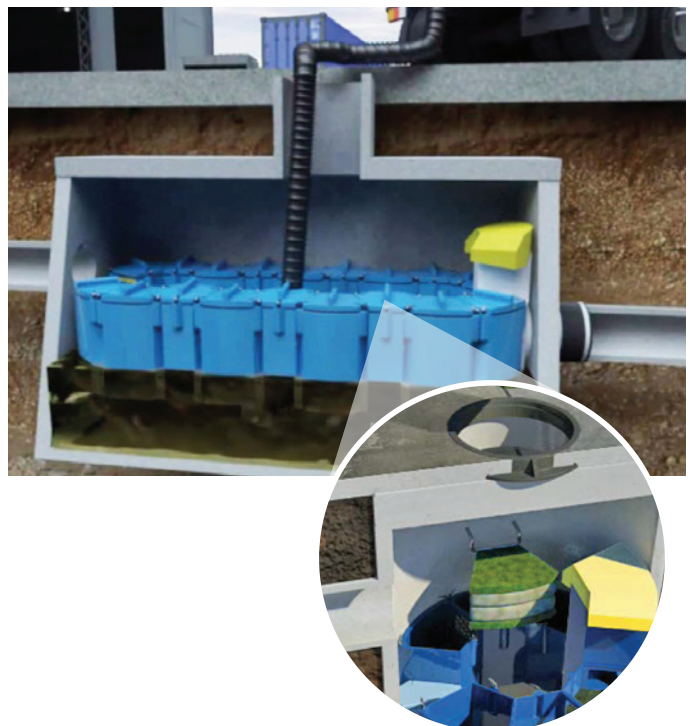

FREE Up-Flo® Filter Sizing Calculator for Engineers

This simple tool will recommend the best filter size and arrangement based on site-specific data entered by the user.

Go to hydro-int.com/sizingtool to access the tool.



Hydro-Brake® Vortex Flow Control

The Hydro-Brake® Vortex Flow Control is a specially designed vortex flow control valve which provides water quantity management for stormwater drainage systems. Its unique vortex flow technology effectively and reliably controls discharge flow across a wide range of operating conditions and applications from small individual plots to large sewer networks. Self-activated and precision engineered, each unit can be custom designed to meet site-specific requirements, offering exceptional flood protection in even the most challenging environments.

The Hydro-Brake® is used to maximize savings on new construction projects by reducing stormwater detention volumes. Also an economical retrofit solution, the Hydro-Brake® can be installed in over-discharging ponds and catch basins to restrict the outflow without requiring the construction of additional detention volumes.

TYPICAL APPLICATIONS

- Outlet flow control for stormwater detention
- Outlet flow control for dams and flood reservoirs
- Reduction of runoff volume from sites
- Erosion control and energy dissipation

| | | | |
|--|---|---|--|
|  COST EFFECTIVE |  VERSATILE |  ADVANCED DESIGN |  EASE OF MAINTENANCE |
| <ul style="list-style-type: none"> • Reduced stormwater storage volumes mean up to 50% savings in project storage costs | <ul style="list-style-type: none"> • Available in wall-mounted or floor-mounted geometries | <ul style="list-style-type: none"> • Area of opening is 3 to 6 times larger than an equivalent orifice | <ul style="list-style-type: none"> • Self-activating with no moving parts or power requirements • Virtually maintenance free |

The Hydro-Brake® operates on simple fluid hydraulics. Flow enters the volute tangentially through the inlet. Under low flow conditions, the Hydro-Brake® acts as a large orifice and water passes directly from the inlet to the outlet (Fig.9a).

As flow increases and reaches the Flush-Flo™ point, high peripheral velocities initiate the throttling action. As head increases, the valve approaches the Switch-Flo™ and Kick-Flo™ points and an air-filled core starts to form in the volute. As head continues to increase, the air core fully stabilizes and the valve discharge is throttled to that of a smaller orifice (Fig.9b).

The Hydro-Brake® Vortex Flow Control optimizes flow control to allow for higher discharge rates at lower heads than conventional flow control options. The head/discharge curves shown below illustrate the behavior of a Hydro-Brake® Vortex Flow Control compared to an orifice (Fig.10).



FIG.10 The characteristic of the Hydro-Brake® vs. an equivalent orifice

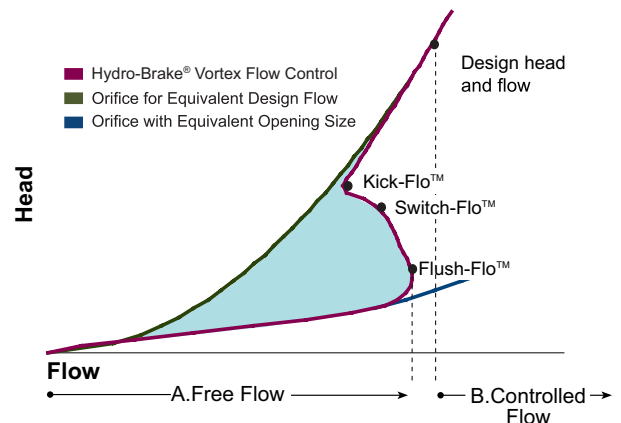

Sizing & Design

Three series of Hydro-Brake® Vortex Flow Controls are available to suit various applications and design constraints. Refer to the Hydro-Brake® Design Chart for typical sizing guidelines (Table 4).

TABLE 4: Hydro-Brake® Vortex Flow Control design chart

| Series | S Series | V Series | C Series |
|-------------------------|--|--|---|
| Typical Geometry |  |  |  |
| Models | SH, STH, SXH, SMH, SMXH | SV, SXV, SMV | C, CX, CH |
| Typical Applications | <ul style="list-style-type: none"> Flow control at the inlet of the storm drain system Outlet flow control for storm water detention systems | <ul style="list-style-type: none"> Erosion control & energy dissipation | <ul style="list-style-type: none"> Outlet flow control for flood dams and levees Outlet flow control for stormwater detention systems |
| Typical Mount Style | Wall Mount | Downspout/Roof Mount Floor Mount, Pipe Mount | Floor Mount |
| Typical Diameter Range* | 50 - 410 mm (2 - 16 in) | 50 - 410 mm (2 - 16 in) | 75 - 510 mm (3 - 20 in) |
| Typical Flow Range** | 1 - 157 L/s (0.05 - 5.6 cfs) | 1 - 174 L/s (0.05 - 6.0 cfs) | 5.3 - 405 L/s (0.18 - 14.3 cfs) |

NOTE:

*Listed diameter ranges are typical guidelines only. Hydro-Brake® Vortex Flow Controls can be manufactured to any specified diameter up to 6 ft.
 **Flow ranges listed are for 4 - 6.5 ft. of head. Contact an Armtec representative for site-specific sizing and design requirements.

Optional Design Accessories

PIVOTING BYPASS DOOR



For maintenance access to the outlet pipe.

CURVED BACKPLATE



To allow for flush-mounting to the wall of a round manhole.

VORTEX SUPPRESSOR PIPE



To eliminate air core for emergency bypass.

Typical Chamber Configurations

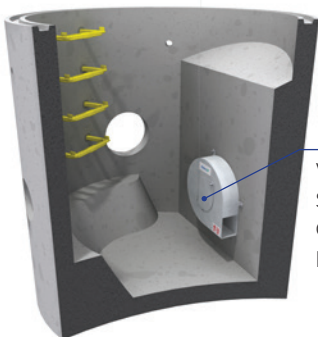

Wall Mounted SXH Model for Catch Basin Inlet Control

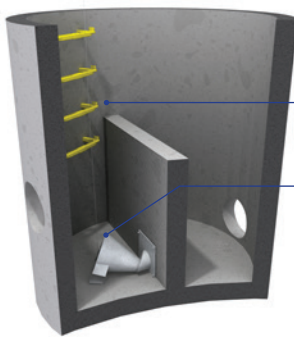

Large Storm Bypass Weir
 Floor Mounted CH Model for Small Storm Flow Control

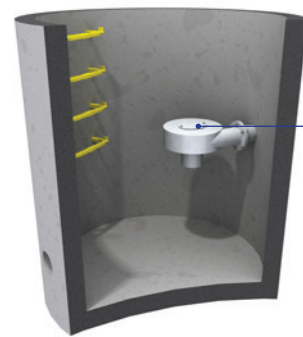

Pipe Mounted SXV Model for Energy & Velocity Dissipation



Armtec is environmentally conscious by supporting limited paper usage.

ATLANTIC

- Shediac, NB
- Sackville, NB
- Truro, NS
- Bishop's Falls, NL
- St. John's, NL

CENTRAL

- Cambridge, ON
- Comber, ON
- Forest, ON
- Guelph, ON
- Orangeville, ON
- Peterborough, ON
- Sudbury, ON
- Thunder Bay, ON
- Walkerton, ON
- Woodstock, ON
- St-Augustin, QC
- St-Clet, QC

PRAIRIES

- Calgary, AB
- Edmonton, AB
- Grande Prairie, AB
- Ponoka, AB
- Redwater, AB
- Winnipeg, MB
- Regina, SK
- Saskatoon, SK

WESTERN

- Dawson Creek, BC
- Genelle, BC
- Langley, BC
- Nanaimo, BC
- Prince George, BC



Platinum member

Find out how our **Stormwater Treatment** and **Flow Control** solutions can be used on your next project.

Call **1-800-565-1152** or visit **armtec.com**